

CHATTERMARKS

**THIS MONTH'S
MEETING DAN
ACKERMAN WILL BE
DEMONSTRATING
LIDDED BOXES**

OCTOBER MEETING

27 OCT 6:30 pm,
Kitsap Adventist School
5088 NW Taylor Rd.
Bremerton, WA

With Social, Library, Show and
Tell Tables and wood auction
viewing before

This month's demonstrator is one of our own club members. Most of you know Dan Ackerman from his past and present participation in the club and its activities. Dan has been turning for almost 30 years and was one of the founding members for the Kitsap Woodturners Club, a chapter of the AAW as it was known then. Dan sat on the national AAW board for two terms and initiated the recording of sessions at the national symposiums. That program has continued to blossom and provide tapes for members to view. In addition, Dan and his wife Kathy ran a production turning gift business which included 22 gift items for 10 years. For the past 6 years Dan has been doing turned boxes of his own design-incorporating turning, carving, inlaying, and sculpting mostly in exotic woods from around the world. Dan will be teaching us how he turns these boxes.

UPCOMING SPECIAL EVENTS MARK YOUR CALENDARS

**Oct 27th Monthly Meeting-Dan
Ackerman on turning boxes**

**Nov 7th ALL DAY OPCAAW Mini-
Symposium. This will be a
great day with several
demonstrations to help you
improve your turning skills**

**Nov 17th Monthly Meeting-Program
to be determined (NOTE this
meeting is earlier than normal
to avoid conflicts with
Thanksgiving)**

**Dec 15th Annual Club Christmas
Party- This will be a great
evening of getting to know
each other, families are
invited. This will be a potluck
dinner. Watch for more details**

Kitsap Adventist School Annual Auction

The school is holding its annual fund raising auction in November. In the past we have donated pieces for them to auction off. The items we have donated in the past always draw a lot of interest and money for the school.

Bring your turnings to donate to the
October meeting.

Nov 7th ALL DAY OPCAAW Mini- Symposium.

If you have a special topic to teach the club see Jimmie during the October Meeting. Plan on attending this great day of turning to learn and share ideas to help everyone improve their skills.

HELP WANTED:

The club is looking for a new member to run the Library. If you have some time to help the club out see any member of the Board or the current librarian, Linda Henderson.

More Help wanted:

The club has lost its contact for buying glue.

If you have a small business license, and would be willing to act as a distributor for the glue company contact any board member for information on how you can support the club and keep us supplied in glue at the special low prices.

From the AAW

The following article is a reprint from the June 1995 issue of the American Woodturning. The American Woodturning a published bimonthly by the AAW for its members. To join and start receiving this magazine and other great benefits go to www.woodturner.org

INTRODUCTION TO CHUCKING

Keeping it sweet and simple

PETER M. SMITH

ONE OF THE FIRST CHALLENGES FOR the turner who wants to make bowls is attaching the block of wood to the lathe. Once the bowl has been shaped, another major challenge is how to finish off the bottom. When people pick up a finished bowl, they invariably turn it over and examine the bottom. Instinctively they realize that's where the bowl must be held on the lathe and they want to figure it out. Good technique means the foot or bottom will be as well finished as the rest of the bowl, and there should be no detracting indication of how the bowl was attached, or chucked, to the lathe.

Of course, in between the first and second challenge, there are plenty of other challenges, but I would like to concentrate on chucking methods here, based on my own experience. I'll address basic chucks first, and then reverse chucks

Basic Chucks

There are several chucks on the market in the \$200 range available for most lathes. These are usually multi-purpose affairs with expanding and contracting jaws. I bought one, and after paying another \$50 to have it properly tapped for my headstock

spindle, I used it once or twice only. It now sits on the shelf waiting for the special case, which never seems to come, where its complexity is needed. While I am sure these chucks are good and serviceable, I prefer the KISS approach—Keep It Sweet and Simple. I have found that two chucks are all that are needed: a screw chuck and a faceplate.

The screw chuck—A good screw chuck will securely hold large blocks of wood. The basic design is straightforward: Usually it's a $\frac{3}{4}$ -inch-long screw extending from a small faceplate. A matching hole is drilled in the wood and the wood screwed onto the chuck. I have seen designs for home-made units where hardware-store lag screws are used, centered through wooden faceplates. However, the critical success factor for this chuck is the design of the screw, and here one product is pre-eminent. Glaser Engineering's screw is designed with a shallow pitch and large flanges that grip the wood almost without fail. Glaser makes two sizes of screw—one with a $\frac{3}{8}$ -inch outside diameter, the other with a $\frac{1}{2}$ -inch outside diameter. Both fit his chuck body; the complete unit is the

Glaser Screw Chuck (about \$100 from supply houses). I use the $\frac{1}{2}$ -inch o.d. screw, and so I drill a $\frac{3}{8}$ -inch hole in the face of the woodblock (approximately 1 inch deep) and spin the block onto the screw chuck. Some persuasion may be necessary, depending on the hardness of the wood. Once the block is tight, this screw will hold wet woods of large diameter, which are really heavy. (For safety considerations, see the sidebar on the facing page.)

When the outside of the bowl has been shaped, a $\frac{3}{4}$ -inch-deep hole can be drilled into the foot, and the block reversed on the chuck. The design of the bowl should allow for 1 inch of waste at the foot, which will be parted off. I fitted a $\frac{3}{8}$ -inch long-bore drill with an old tool handle, but I've also held a regular drill with a vise-grip. You have to be careful not to drill too deep, or the drill hole will go through the eventual bottom of the bowl, which is not recommended.

Immediately one benefit of the single screw hole can be seen—the reversed block should be almost perfectly centered. Work can now begin on the inside.

We can extend the approach even

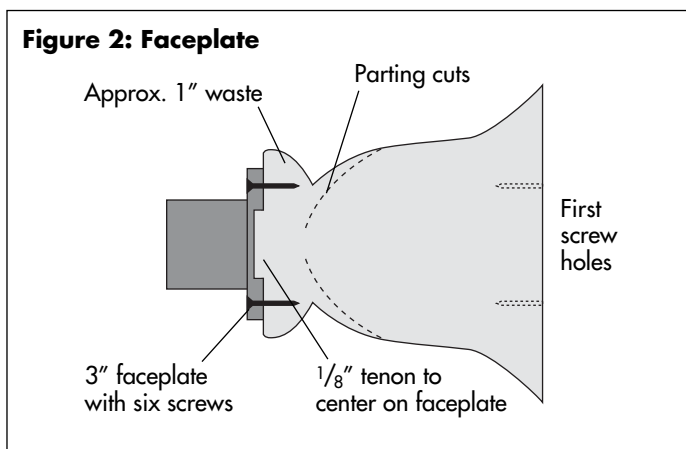
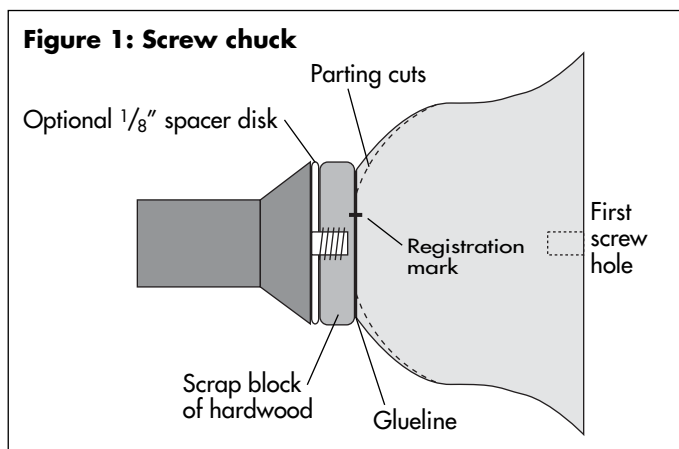

**Figure 3:
Jam chuck**

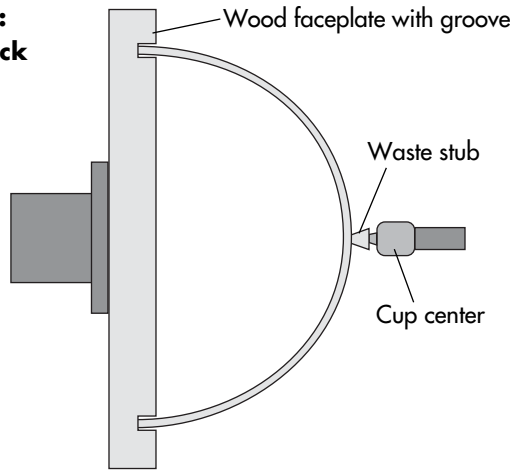
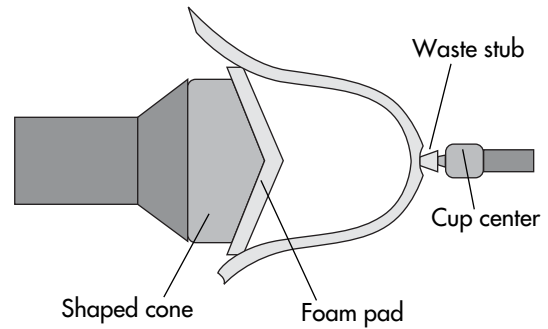

Figure 4: Jam chuck for irregular-edged work



more by using scrap blocks of hardwood glued to the (flattened) bottom of the bowl via cyanoacrylate glue, and drilling the hole in this after starting a hole with a narrow gouge (Figure 1). This is useful if the design requires using the full block of wood. Hardwood scraps are necessary; plywood separates and fiberboard crumbles. The scrap is turned to a circle and eventually parted off.

Another tip here is to use a $1/8$ -inch plywood disk on the chuck to shorten the screw penetration into the wood. This is particularly useful for small pieces. If the wood is soft, a few drops of thin cyanoacrylate will harden up the drill hole.

Mark the position of the scrap relative to the bowl with a pencil or black marker, in case the bowl breaks off after a catch, or when it dries and warps.

Which brings us to another major advantage of the single-screw chuck: Once the bowl has dried for three or more months and stopped warping, and you now need to remount, true up, and finish it, the single hole is there for you, centered and ready.

The faceplate—For large blocks which even the Glaser screw will not hold, a face-plate and screws will be required. Large faceplates are not necessary except for starting on really big blanks (greater than 20 inches in diameter). It's hard to get a large enough flat surface on raw blanks, and a large faceplate limits access when used on the bottom of a

bowl. A 3-inch faceplate is best, but it should be drilled for six screws. And the type of screws is important—sheet-metal screws with a uniform shank and square-drive pan head are my preference. Drywall screws are tempting because they are sharp and easy; however they are also brittle and will shear under stress, so they should not be used. Six $1\frac{1}{4}$ -inch screws which penetrate 1 inch into the wood will hold most blocks other than decayed, punky wood, which can be hardened with cyanoacrylate. When the faceplate is used for the initial shaping, it is attached to the face of the block; and then it is attached to the bottom of the bowl, ei-

ther to the wood itself (Figure 2), or to the scrap block if required by the design. It is sometimes necessary to drill pilot holes in the scrap block.

It is helpful to raise a $1/8$ -inch-long tenon on the bottom of the blank, its width equal to the inside diameter of the faceplate. This will assist in centering the faceplate.

Reverse Chucks

There are several approaches to completing the foot of the bowl. I will discuss three: the jam chuck, the vacuum chuck, and the ring chuck. Each requires investment in time and money before it can be used, but this investment has to be made if the job is to be done right.

The jam chuck—This is the simplest device for reverse chucking: it is a wooden disk with a groove turned into it to match the diameter of the bowl. The bowl is reversed onto the disk and held in the groove by a snug fit, the groove serving also to center the bowl. The tailstock is brought up to help keep the piece in place. At low revolutions and with light cuts, the foot is shaped, leaving a small stub at the tailstock point (Figure 3). This stub will finally be chiseled off and the spot sanded to blend in.

The wooden disk can be held via faceplate or screw chuck. It can be any material—plywood is fine. One jam chuck disk is used per bowl, so you end up with a pile of disks of various diameters, but they can be reused with smaller-diameter bowls.

Safety Considerations

- Blocks of wet wood are heavy and uneven. Use the tailstock with revolving center to keep the wood up against the chuck, especially with the single screw, but also with the faceplate, until the block is true.
- Start with very slow revolutions; a variable-speed DC motor makes a great difference here.
- Always wear a face shield (not just goggles). Stand aside from the plane of rotation.
- Be able to stop your lathe as soon as there is a problem—use a foot switch or a switch placed near the tailstock.

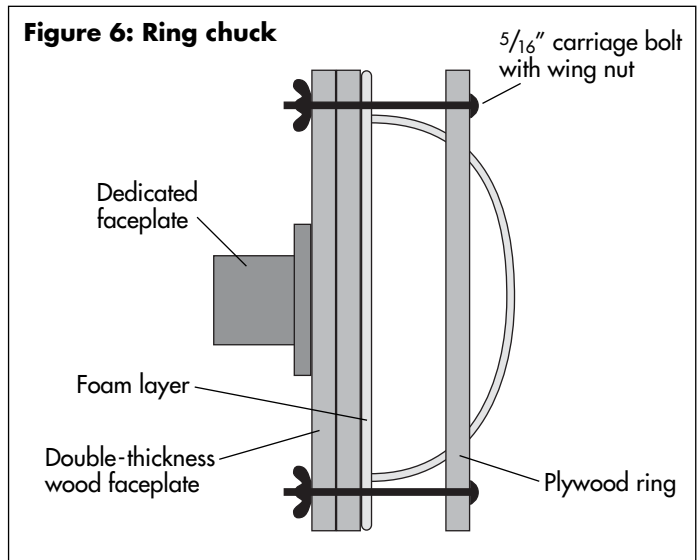
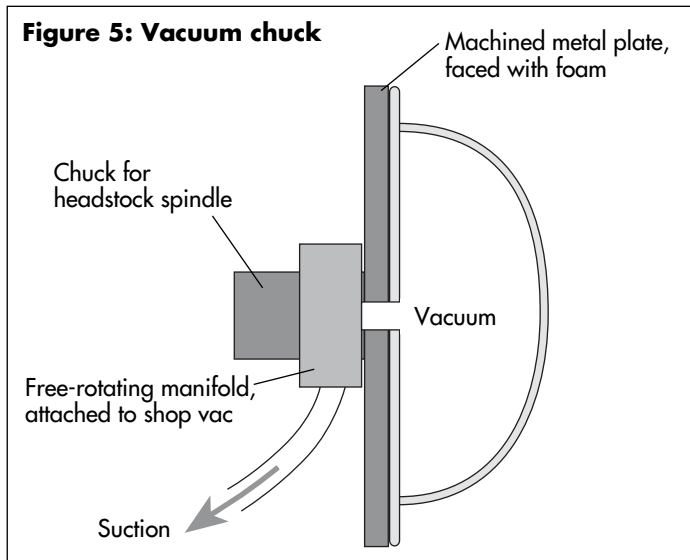

The tailstock support also works for irregular- or natural-edged bowls, when a foam-padded cone is used inside the bowl to jam against (Figure 4, page 17). The cone is readily made from scrap wood to match the unique size and shape of the bowl; at its simplest it is the waste block left behind when the bowl is parted off.

This approach is pretty straightforward and works well, except that you have to find large disks of scrap wood and cut the groove to match, and fuss with the little stub at the end. By comparison, the vacuum chuck is more attractive.

The vacuum chuck—This is an advance over the basic jam chuck: atmospheric pressure holds the bowl against the faceplate, thus obviating the need for a groove (since the workpiece can be easily centered) and the tailstock (since air pressure is strong enough to hold it in place in most cases).

There are two types of vacuum chuck: One uses a suction tube centered in a wooden faceplate and fed through the headstock spindle. It uses a small vacuum pump. The other uses a shop-vac attached to a rotating collar behind a metal, engineered faceplate faced with a foam pad (Figure 5). The former fitting can be obtained from Packard Woodworks (704/859-6762) for \$50;

the latter from Craft Supplies USA (800/551-8876) for \$160. I chose the shop-vac unit since shop-vacs are easily found (KISS again), and although I have not been using it for long, I like it despite the noise. For the right shape of bowl, the suction is tight and allows fast, effective finishing of the complete bowl foot. For larger bowls and odd shapes, or designs with uneven edges, this chuck is not so suitable, and I sometimes resort to using the tailstock for reinforcement. I intend to build, as needed, special-purpose wooden enhancements to the suction plate to deal with more complex shapes such as vases, although in these cases I find I can just as well use the tailstock and avoid the din of the shop-vac.

The ring chuck—Tried and true, the homemade ring chuck consists of a faceplate disk and a wooden ring which holds the bowl to the plate via bolts and wing nuts (Figure 6). Various lengths of bolts, and various diameter rings, are made to accommodate any bowl of diameter less than that of the faceplate.

Readily constructed in an afternoon out of plywood, the faceplate is double-thick and covered with thin foam rubber. The rings are of the same diameter as the faceplate, and have three matching holes for the $\frac{5}{8}$ -inch carriage bolts; register marks on

each ring ensure the bolt holes line up. The inner diameter of the rings varies from narrow to wide; three or four can be made and the inner edges rounded over with a router to prevent marring the bowl.

The reversed bowl is held in place via the appropriate ring and length of bolt. The closer the ring can be to the faceplate, the more secure the bowl is against being bumped out of true. The bowl is then centered carefully (bring up the tailstock to register it) before tightening the bolts. I have seen designs where a stepped cone is added to the center of the faceplate to provide for rapid centering. When the lathe is turned on (at low revs, I hasten to add), the foot is wholly available for finishing. Again, light cuts with small gouges are recommended.

Summary

For the primary attachment of wood to a lathe, you can get by in most cases with the Glaser chuck, some scrap hardwood disks, and the ubiquitous, invaluable cyanoacrylate glue. To finish the bottom of a bowl, the bowl is held against a large home-made faceplate by the tailstock, suction, or a ring, the latter two leaving the foot completely clear for proper attention.

Peter Smith manages computer applications and turns in Princeton, NJ.

MENTORING PROGRAM

We are looking for some new mentors. The folks who are currently doing this great service have been doing it for a long time. See any of the board officers if you are interested.

The mentoring programs has been set up to answer questions and give help to new members and those whom may be having a problem in a specific area. Although not intended to be free lessons in woodturning (many of those volunteering are professional turners and derive their income from turning and teaching), these are some friendly folks willing to give you a point in the right direction.

Dan Ackerman..... (360) 796-4155
"Tones" Briggs..... (360) 871-7607
George Kromka (360) 373-1028
Jim Leary..... (360) 297-5872
Bob(Hicke)Hinkernell.....(360) 479-5501

Chapter Officers

| | | | |
|--|----------------|---------------|----------------------------|
| President | Doug Henderson | (360)437-4033 | President@opcaaw.com |
| Vice President of Education and Training | Jimmie Allen | (360)373-3041 | Training@opcaaw.com |
| Vice President of Public Relations | Ralph Lindberg | (360)779-5979 | PublicRelations@opcaaw.com |
| Secretary | Vern West | (360)479-8634 | Secretary@opcaaw.com |
| Sergeant at Arms | Eric Fehrmann | (360)457-1380 | SargeantAtArms@opcaaw.com |
| Treasurer | George Willock | (360)871-1643 | Treasurer@opcaaw.com |
| Vice President of Membership | Scott Overby | (360)895-8626 | Membership@opcaaw.com |
| Vice President of Special Events | Cindy Allen | (360)373-3041 | Training@opcaaw.com |
| CHATTERMARKS Editor | Larry Hamon | (360)204-6799 | Editor@opcaaw.com |

Our Sponsors....

These companies have supported our club's Christmas Party. Support them and if you use one of them, let them know that you appreciate their contribution to the club.

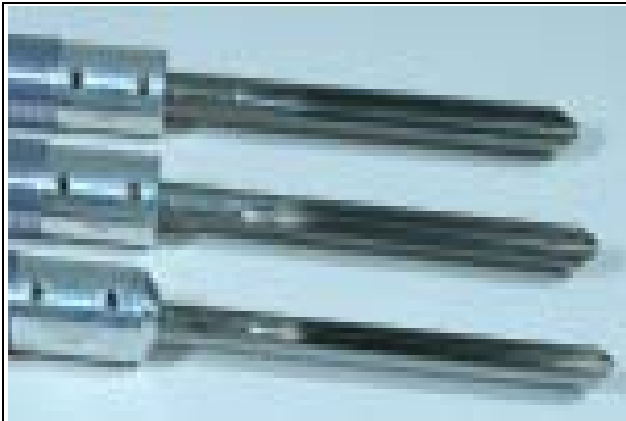

Simply the best turning tools available

All tools are made from Premium M42 Cobalt High Speed Steel.

Contact Dave at

<http://www.d-waytools.com>

or call 1-360-432-9509 for info on how to purchase any of D-Ways great Turning tools.

Woodturning Gouges, Hollowing Tools, Beading Tools and Handles are available.

D-Way Tools

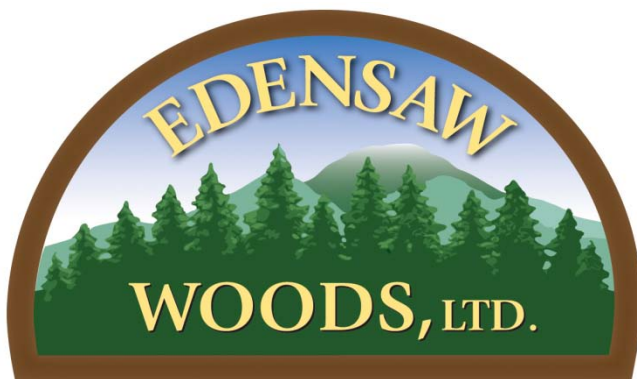

EDEN SAW WOODS LTD

211 SETON ROAD
PORT TOWNSEND, WA 98368
(360)385-7878 (800)745-3336

Store Hours 8-5 Mon-Fri 9-4 Sat

E-mail rainier@edensaw.com

Packard Woodworks, Inc.



CATALOG for WOODTURNERS

Call Toll Free...(800)-683-8876

Fax: (828)859-5551

E-Mail:

packard@alltel.net

Web site:

<http://www.packardwoodworks.com>



CRAFT SUPPLIES USA
THE WOODTURNERS CATALOG

1-800-551-8876

Serving Woodturners for over 25 years

Call or write for FREE color catalog

1287 E. 1120 S.

Provo, Utah 84606 USA

TEL: 800-551-8876

www.woodturnerscatolog.com



CHOICE WOODS

2801 S. Floyd Street, Suite 100,

Louisville KY 40209

Phone 502-637-1190 or 888-895-7779

email clay@choice-woods.com

Web <http://www.choice-woods.com>

D S C Industrial Supply

For all your woodworking needs

Jet Tool & Equipment
Milwaukee Electric
Porter-Cable

Performax
Powermatic
Hitachi



3203 Totten Rd NE,
Poulsbo (Old Big Bear Drive-In)

<http://www.dscindustrial.com/>

Phone: 360-697-3280 Fax: 360-697-4326

Equipment Sales and Surplus

Woodworking, Metalworking & Material Handling

Distributors of New and Surplus tools from
JET, Powermatic, Performax, Wilton, and Oliver
1801 West Valley Hwy N. Suite 105
Auburn, WA 98001

Neil Ferko, President 253-804-3211

neil@equipmentsalesandsurplus.com

866-831-0722 toll free fax 253-804-8500

<http://www.equipmentsalesandsurplus.com>

Custom Craft Wood and Veneer

Jay Parmenter

(541)-659-4388

560A NE F Street PMB 124
Grants Pass OR 97526

parmenter@charter.net